

**National Pollutant Discharge Elimination System/State Disposal System**

**MN0020567**

**Permittee:** City of Monticello  
**Facility name:** Monticello Wastewater Treatment Facility  
**Receiving water:** Mississippi River - Class 1C, 2Bdg, 3, 4A, 4B, 5, 6 water  
**City:** Monticello **County:** Wright  
**Issuance date:** TBD  
**Expiration date:** TBD

The state of Minnesota, on behalf of its citizens through the Minnesota Pollution Control Agency (MPCA), authorizes the Permittee to operate a disposal system at the facility named above and to discharge from this facility to the receiving water named above, in accordance with the requirements of this permit.

The goal of this permit is to reduce pollutant levels in point source discharges and protect water quality in accordance with the U.S. Clean Water Act, Minnesota statutes and rules, and federal laws and regulations.

Although this permit is effective on the issuance date identified above, the limits and monitoring requirements are not effective until XX/01/XXXX. This permit is effective on the issuance date identified above. This permit expires at midnight on the expiration date identified above.

Signature: *[Type e-Signature]*

*This document has been electronically signed.*

*for the Minnesota Pollution Control Agency*

Benjamin Carlson-Stehlin  
Supervisor  
Metro Regional and Infrastructure Financing Unit  
Municipal Division

## Resources

Submit electronic Discharge Monitoring Reports (eDMR) via the MPCA e-Services at: [https://rsp.pca.state.mn.us/TEMPO\\_RSP/Orchestrate.do?initiate=true](https://rsp.pca.state.mn.us/TEMPO_RSP/Orchestrate.do?initiate=true)

Submit documents electronically to [wq.submittals.mpca@state.mn.us](mailto:wq.submittals.mpca@state.mn.us). **Note:** The Water quality submittals form located at <https://www.pca.state.mn.us/sites/default/files/wq-wwprm7-71.docx> must be attached.

For eDMR and other permit reporting issues, use the directory listed at the bottom of the Discharge Monitoring Report page: <https://www.pca.state.mn.us/water/discharge-monitoring-reports>

For specific permit requirements, contact your compliance staff: <https://www.pca.state.mn.us/water/wastewater-compliance-and-enforcement-staff-contacts>

For wastewater permit program general questions, contact the MPCA at 651-282-6143 or 800-657-3938, or reference the permit user's manual at <https://www.pca.state.mn.us/sites/default/files/wq-wwtp7-09.pdf>.

Additional guidance and resources are located at: <https://www.pca.state.mn.us/water/wastewater>.

A printable summary of sampling requirements can be found at: <https://www.pca.state.mn.us/water/wastewater-permit-submittal-checklists>.

A printable checklist of submittals can be found at: <https://www.pca.state.mn.us/water/wastewater-permit-submittal-checklists>

## Table of Contents

	Page
1. Permitted facility description.....	4
2. Location map of permitted facility.....	5
3. Flow diagram.....	6
4. Summary of stations and station locations.....	7
5. Permit requirements.....	8
6. Submittal action summary .....	29
7. Limits and monitoring.....	30

DRAFT

## 1. Permitted facility description

The Monticello Wastewater Treatment Facility (facility) is located at 1401 Hart Boulevard, Monticello, Minnesota 55362-8654, Wright County.

The existing facility has a continuous discharge from SD 001. The facility is a Class A.

The facility is designed to treat:

- an average wet-weather (AWW) flow of 2.360 million gallons per day (mgd)
- an average dry-weather (ADW) flow of 1.790 mgd
- five-day biochemical oxygen demand (BOD<sub>5</sub>) of 9,211 pounds per day (lbs/day) at AWW flow

The facility consists of screening, grit removal, three sequencing batch reactors, chemical addition for phosphorus removal, and chlorination/dechlorination. Biosolids treatment consists of dissolved air flotation, primary and secondary anaerobic digestion, storage tanks, and screw press dewatering. Biosolids are land applied and landfilled.

Changes to the facility may result in an increase in pollutant loading to surface waters or other causes of degradation to surface waters. If a change to the facility will result in a net increase in pollutant loading or other causes of degradation that exceed the maximum loading authorized through conditions specified in the existing permit, the changes to the facility are subject to antidegradation requirements found in Minn. R. 7050.0250 to 7050.0335.

The Mississippi River - Class 1C, 2Bdg, 3, 4A, 4B, 5, 6 water was designated an Outstanding Resource Value Water (ORVW) on November 5, 1984.

This Permit also complies with Minn. R. 7053.0275 regarding anti-backsliding.

Any point source discharger of sewage, industrial, or other wastes for which a National Pollutant Discharge Elimination System (NPDES) permit has been issued by the MPCA that contains effluent limits more stringent than those that would be established by Minn. R. 7053.0215 to 7053.0265 shall continue to meet the effluent limits established by the permit, unless the permittee establishes that less stringent effluent limits are allowable pursuant to federal law, under section 402(o) of the Clean Water Act, United States Code, title 33, section 1342.

## 2. Location map of permitted facility

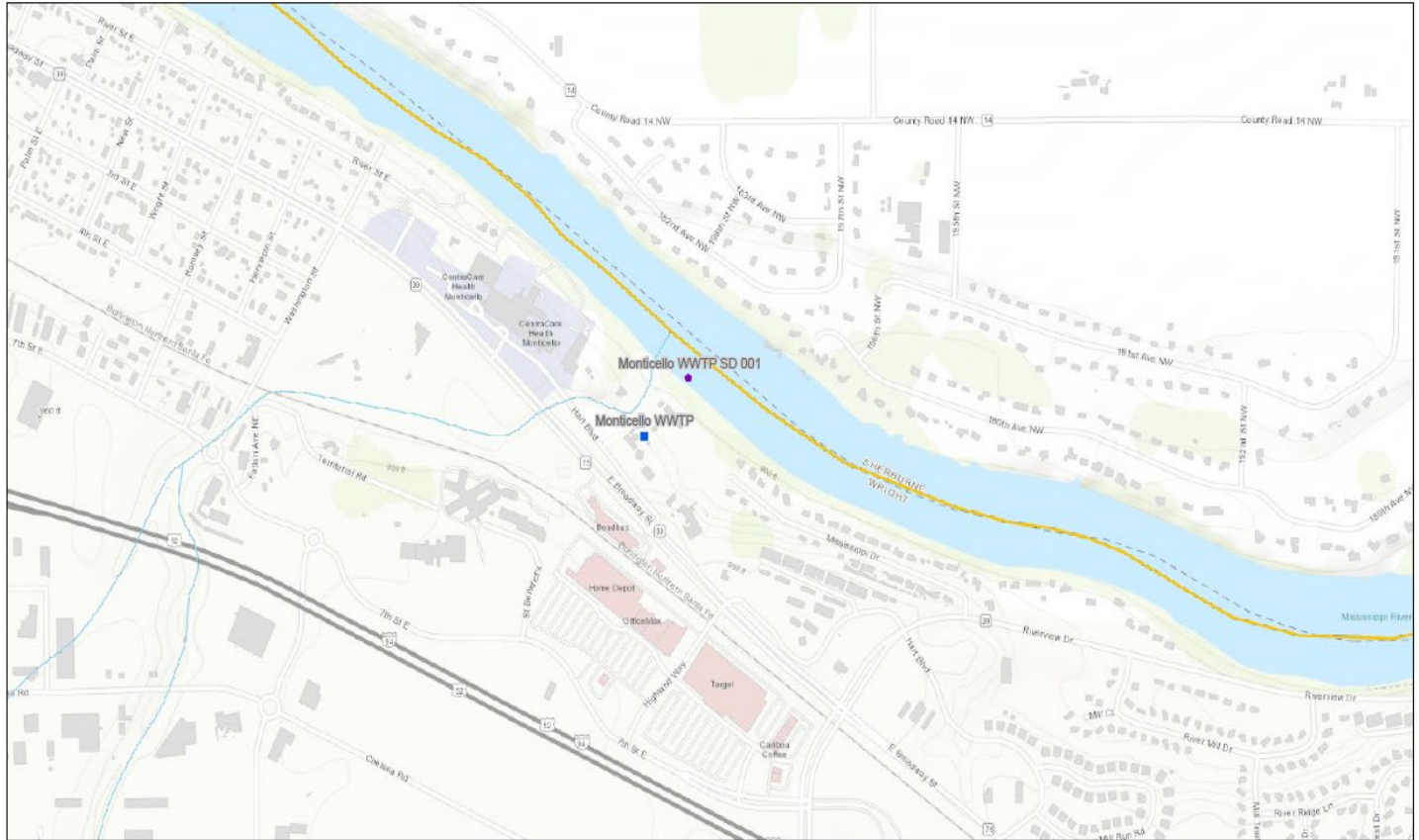

2/4/2025, 11:26:37 AM

Facility by waste type - active

- Domestic - NPDES/SDS

1:10,916

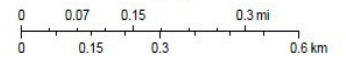

3. Flow diagram

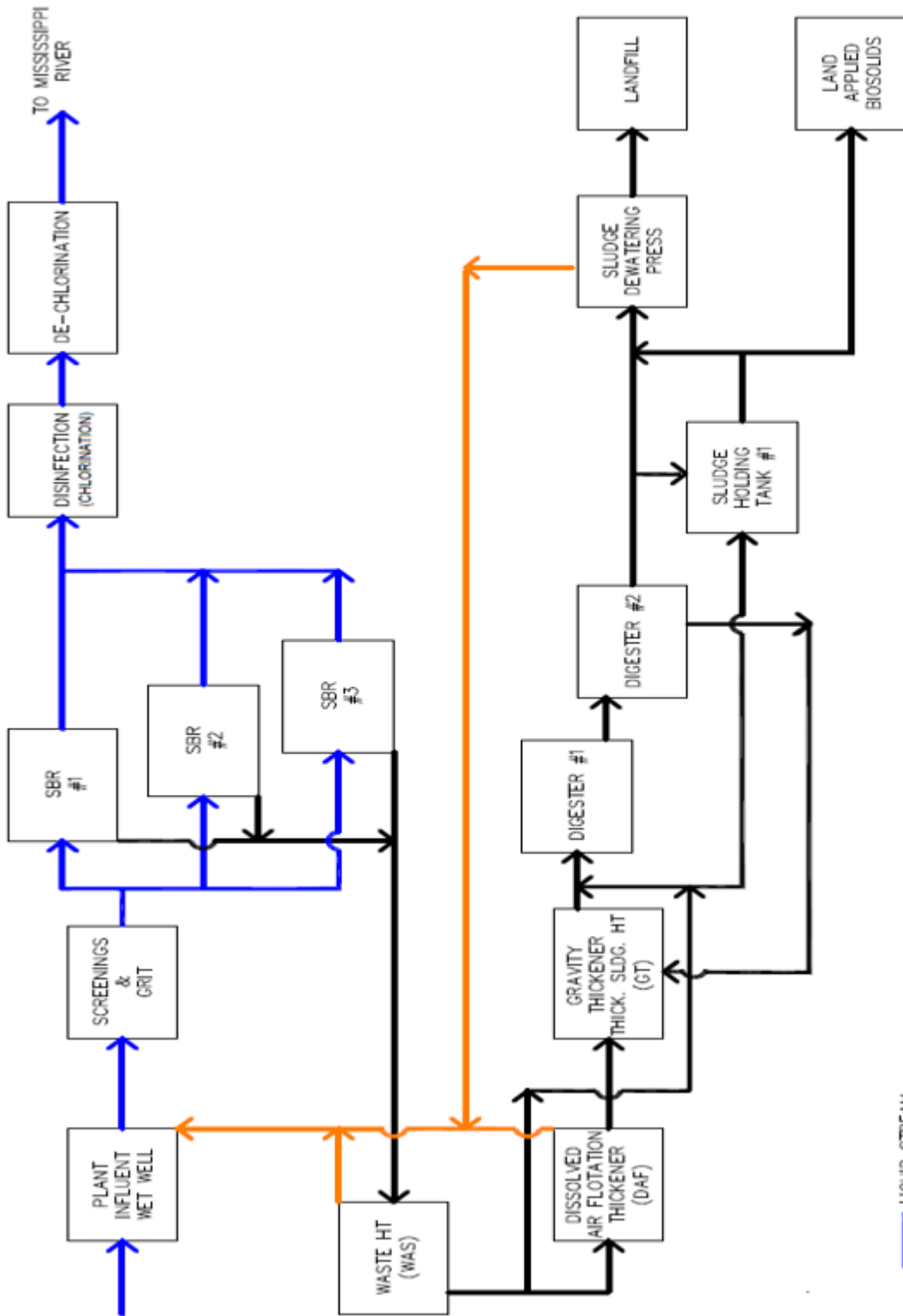

— LIQUID STREAM  
— SOLIDS STREAM  
— SUPERNATANT / RETURN

**4. Summary of stations and station locations**

<b>Station</b>	<b>Type of station</b>	<b>Local name</b>	<b>PLS location</b>
SD 001	Effluent To Surface Water	Surface Water Discharge	T121N, R25W, S12, SW Quarter of the SE Quarter
WS 001	Influent Waste	Influent Waste Stream	T121N, R25W, S12, SW Quarter of the SE Quarter

DRAFT

5. Permit requirements

SD 001	Effluent To Surface Water	
<b>Surface Discharge: Class A Major Facility Effluent Requirements</b>		
5.1.1		The Permittee shall submit a monthly DMR: due by 21 days after the end of each calendar month following permit issuance. [Minn. R. 7001.0150, subp. 2(B)]
5.1.2		<b>Sampling Location.</b> [Minn. R. 7001.0150, subp. 2(B)]
5.1.3		Samples for Station SD 001 shall be taken from the final outlet control structure and shall be representative of the total facility discharge. [Minn. R. 7001.0150, subp. 2(B)]
<b>Acute Toxicity Requirements</b>		
5.2.4		<b>Definitions.</b> [Minn. R. 7001]
5.2.5		"Acute Whole Effluent Toxicity (WET) Test" is a static renewal test conducted on an exponentially diluted series of effluent. The purpose is to calculate the proportion of effluent that causes 50% mortality/immobility of aquatic organisms at 48 hours for Daphnia magna and Ceriodaphnia dubia or 96 hours for fathead minnows. An LC50/EC50 (lethal/immobile concentration) less than or equal to 100% effluent constitutes a positive for toxicity. [State Definitions]
5.2.6		"Acute toxic unit (TUa)" is the reciprocal of the effluent dilution that causes the acute effect by the end of the acute exposure period. For example, a TUa equals (100% effluent)/(48 hour LC50/EC50 for Daphnia magna and Ceriodaphnia dubia or 96 hour LC50/EC50 for fathead minnows in %). [State Definitions]
5.2.7		"Test" refers to an individual species. [State Definitions]
5.2.8		"Test Battery" consists of WET testing of each species associated with each specified acute test. For acute WET testing, all test species includes fathead minnows, Daphnia magna, and Ceriodaphnia dubia. [State Definitions]
5.2.9		<b>General Requirements.</b> [Minn. R. 7001]
5.2.10		This permit does not include an acute WET limit; however, the facility has a WET testing monitoring requirement and is required to conduct acute toxicity tests from outfall Station SD 001. Results of acute toxicity tests will be evaluated against a monitoring threshold value of 0.9999 TUa. [Minn. R. 7052, Minn. R. 7053]
5.2.11		The Permittee shall submit annual acute toxicity test battery results : Due 180 calendar days after Permit Issuance Date annually thereafter. [Minn. R. 7001]
5.2.12		Additional WET tests are required for each year that exceeds the five-year permit cycle if the permit is not immediately reissued after permit expiration. The WET testing results are due on the same date as the original requirement, annually, until the permit is reissued. [Minn. R. 7001]
5.2.13		Any test that exceeds 0.9999 TUa shall be re-tested according to the Positive Toxicity Results requirement(s) that follow to determine if toxicity is still present above 0.9999 TUa. [Minn. R. 7001]
5.2.14		<b>Species and Procedural Requirements.</b> [Minn. R. 7001]
5.2.15		Tests shall be conducted in accordance with procedures outlined in EPA-821-R-02-012 Methods for Measuring the Acute Toxicity of Effluents and Receiving Waters to Freshwater and Marine Organisms - Fifth Edition (Acute Manual) and any revisions to the Acute Manual. [Minn. R. 7001]
5.2.16		Any test that begins with an effluent sample that is equal to or exceeds a total ammonia concentration of 5.0 mg/L may use the carbon dioxide-controlled atmosphere technique to control pH drift. [Minn. R. 7001]
5.2.17		Test organisms for each test battery shall include the fathead minnow (Pimephales promelas)-Method 2000.0, Ceriodaphnia dubia-Method 2002.0, and Daphnia magna-Method 2021.0 or any updates to these methods. [Minn. R. 7001]
5.2.18		Static renewal acute serial dilution tests of the effluent shall consist of a control, 12%, 25%, 50%, 75%, and 100% effluent. [Minn. R. 7001]

5.2.19	All effluent samples shall be flow proportioned 24-hour composite samples. Test solutions shall be renewed daily. Testing of the effluent shall begin within 36 hours of sample collection. Receiving water collected outside of the influence of discharge shall be used for dilution and controls. [Minn. R. 7001]
5.2.20	Any other circumstances not addressed in the previous requirements or that require deviation from that specified in the previous requirements shall first be approved by the MPCA. [Minn. R. 7001]
5.2.21	<b>Quality Control (QC) and Report Submittals.</b> [Minn. R. 7001]
5.2.22	Any test that does not meet quality control measures or results which the Permittee believes reflect an artifact of testing (i.e. poor control results) shall be repeated within two weeks of notification from the lab regarding the test sample results. The acute WET report and QC reports shall contain information consistent with the report preparation section of the Acute Manual. The MPCA shall make the final determination regarding test validity. [Minn. R. 7001]
5.2.23	<b>Positive Toxicity Result for WET.</b> [Minn. R. 7001]
5.2.24	Should a test exceed 0.9999 TUa for WET based on results from the most sensitive test species, the Permittee shall conduct two repeat test batteries on all species. The repeat tests are to be completed within 45 days after completion of the positive test. These tests are used to determine if toxicity exceeding 0.9999 TUa remains present for any test species. [Minn. R. 7001]
5.2.25	<b>Repeat Testing Results.</b> [Minn. R. 7001]
5.2.26	<b>Negative Retests.</b> If no toxicity is present above 0.9999 TUa for any test species in both repeat tests, the Permittee shall return to the test frequency specified by the permit. [Minn. R. 7001]
5.2.27	<b>Positive Retests.</b> If toxicity is present above 0.9999 TUa for any test species in either of the repeat tests, the Permittee shall submit a plan for conducting a Toxicity Reduction Evaluation (TRE) for MPCA review and approval. [Minn. R. 7001]
5.2.28	<b>TRE Requirements.</b> [Minn. R. 7001]
5.2.29	<p>The TRE shall be submitted within 60 days after the toxicity discovery date and include a Facility Performance Review. Upon approval of the TRE, the Permittee shall implement the TRE or subsequent amendments in its entirety. Any violations of the TRE are violations of this permit.</p> <p>In addition, quarterly reports starting from the date of the TRE submittal are required. The quarterly reports shall include, but are not limited to, a complete description of all progress made towards the identification of the source(s) of toxicity and the Permittee's plans for the removal of the toxicity. The TRE shall be consistent with the Acute Manual or subsequent procedures approved by the MPCA in attempting to identify and remove the source of the toxicity. Routinely schedule acute toxicity test batteries required in this permit shall remain in effect throughout the permit cycle.</p> <p>The Permittee must submit a request to discontinue the TRE for MPCA review upon conclusion of the TRE. If the MPCA discontinues the TRE, the permit may be modified to set conditions to be met by the Permittee based on the TRE results. If the MPCA continues the TRE, the Permittee shall continue to implement the approved conditions of the TRE. [Minn. R. 7001]</p>
5.2.30	Following successful completion of the TRE, the Permittee shall conduct semi-annual testing for the next five-year permit cycle. [Minn. R. 7001]
5.2.31	<b>WET Data and Test Acceptability Criteria (TAC) Submittal.</b> [Minn. R. 7001]
5.2.32	<p>All WET test data and TAC shall be submitted to the MPCA by the dates required by this section of the permit using the MPCA Acute Whole Effluent Toxicity Test Report found on the MPCA website at <a href="https://www.pca.state.mn.us/business-with-us/wastewater-permit-additional-guidance-and-information">https://www.pca.state.mn.us/business-with-us/wastewater-permit-additional-guidance-and-information</a>.</p> <p>Data not submitted on the correct form(s), or submitted incomplete, will be returned to the Permittee and deemed incomplete until adequately submitted on the designated form(s). These are legal forms and must be signed and dated by the Permittee. [Minn. R. 7001]</p>
5.2.33	<b>Potential Permit Modifications.</b> [Minn. R. 7001]

5.2.34	The permit may be modified during a permit cycle to include additional toxicity testing and/or a WET limit based on the WET testing results. [Minn. R. 7001]
	<b>Priority Pollutant Requirements</b>
5.3.38	<b>Monitoring Frequency.</b> [Minn. R. 7001]
5.3.39	The Permittee shall monitor the effluent three times in the life of the permit for the following specified priority pollutants. Sampling events shall occur before the second, third, and fourth year following permit issuance and shall not be less than one year apart. [Minn. R. 7001]
5.3.40	The Permittee shall submit the first priority pollutant monitoring report: due 1095 calendar days before Permit Expiration Date. (By two years after permit issuance date). [Minn. R. 7001]
5.3.41	The Permittee shall submit the second priority pollutant monitoring report: due 730 calendar days before Permit Expiration Date. (By three years after permit issuance date). [Minn. R. 7001]
5.3.42	The Permittee shall submit the third priority pollutant monitoring report: due 365 calendar days before Permit Expiration Date. (By four years after permit issuance date). [Minn. 7001]
5.3.43	<b>Sample Type.</b> [Minn. R. 7001]
5.3.44	All samples should be collected using a 24-hour flow proportional composite; except for the 624 volatiles, cyanide, and 1631E mercury samples, which must be collected using the grab method. [Minn. R. 7050.0222]
5.3.45	<b>Reporting Specifics.</b> [Minn. R. 7001]
5.3.46	Reporting limits for all Priority Pollutant analyses shall be as close as analytically possible to the Class 2Bd chronic water quality standards. [Minn. R. 7050.0222]
5.3.47	<b>Monitoring Specifics.</b> [Minn. R. 7001]
5.3.48	<p>Monitoring shall be for the organic priority pollutants identified under the volatile, acid, base/neutral, and pesticide fractions using EPA methods 624, 625, and 608 (40 CFR pt. 136) as listed in Table II of 40 CFR pt. 122, Appendix D or any updates to those methods.</p> <p>The following priority pollutant total metals shall also be monitored using EPA approved methods found in Table IB of the current version of 40 CFR pt. 136: antimony, arsenic, beryllium, cadmium, chromium, copper, lead, nickel, selenium, silver, thallium, and zinc. In addition, the Permittee shall monitor for total cyanide, total phenolic compounds, and hardness (total as CaCO<sub>3</sub>) using methods approved in the most recent update of 40 CFR pt. 136.</p> <p>Total mercury shall be monitored by EPA method 1631E or the most recent update to this method, if not already required by the permit.</p> <p>Total cyanide shall be monitored to the free cyanide water quality standard.</p> <p>The chromium reporting limit shall meet the chromium +6 water quality standard. [Minn. R. 7001]</p>
	<b>Facility Specific Requirements</b>
5.4.52	<b>Salty Discharge Monitoring Requirements.</b> [Minn. R. 7001]
5.4.53	The facility has a salty waste stream from a food processing industry; therefore, the following salty discharge parameters have been included in the permit: total chloride, total dissolved solids, specific conductivity, and total sulfate. [Minn. R. 7001]
5.4.54	The Permittee may request a reduction in salty discharge monitoring if, after two years of data and a minimum of 10 samples have been collected, the monitoring does not indicate a reasonable potential to exceed a water quality standard limit. [Minn. R. 7001]
5.4.55	If salty discharge monitoring results indicate a reasonable potential for any of the parameters, the Permittee will be required to submit an application for permit modification. If necessary, a compliance schedule will be added to the permit to ensure process towards meeting the water quality standards. [Minn. R. 7001]

WS 001	Influent Waste	
		<b>Waste Stream: Class A Major Facility Influent Requirements</b>
	5.5.1	The Permittee shall submit a monthly DMR: due by 21 days after the end of each calendar month following permit issuance. [Minn. R. 7001.0150, subp. 2(B)]
	5.5.2	<b>Sampling Location.</b> [Minn. R. 7001.0150, subp. 2(B)]
	5.5.3	Samples for Station WS 001 shall be taken at a point representative of total influent flow to the system. [Minn. R. 7001.0150, subp. 2(B)]
MN0020567	Monticello WWTP	
		<b>Surface Discharge Station General Requirements</b>
	5.6.1	<b>Surface Discharge Prohibitions.</b> [Minn. R. 7001]
	5.6.2	Floating solids or visible foam shall not be discharged in other than trace amounts. [Minn. R. 7001]
	5.6.3	Oil or other substances shall not be discharged in amounts that create a visible color film. [Minn. R. 7001]
	5.6.4	The Permittee shall install and maintain outlet protection measures at the discharge stations to prevent erosion. [Minn. R. 7001]
	5.6.5	<b>Winter Sampling Conditions.</b> [Minn. R. 7001]
	5.6.6	The Permittee shall sample flows at the designated monitoring stations including when this requires removing ice to sample the water. If the station is completely frozen throughout a designated sampling month or if unsafe ice conditions exist, the Permittee shall check the "No Discharge/No Flow" box on the eDMR and note the ice conditions in the comments on the eDMR. [Minn. R. 7001]
	5.6.7	<b>Chlorine Addition Requirements.</b> [Minn. R. 7001]
	5.6.8	If chlorine is added for any purpose, the Permittee shall monitor the discharge for Total Residual Chlorine (TRC) once per day during chlorine usage. The Permittee shall report the monitoring data on the Sample Values and eDMR in months monitoring is required.  If chlorine is added for any purpose outside of the effective period listed in the Limits and Monitoring section of the permit, the data should be submitted as a comment on that month's eDMR. The discharge shall not exceed a 0.038 mg/L TRC limit. [Minn. R. 7001]
	5.6.9	<b>Sampling Collection and Reporting.</b> [Minn. R. 7001]
	5.6.10	The Permittee shall submit monitoring results in accordance with the Limits and Monitoring requirements for this station. If conditions are such that no sample can be acquired, the Permittee shall check "No Discharge/No Flow" on the eDMR and shall add a comment to the eDMR detailing why the sample was not collected. [Minn. R. 7001.0150, subp. 2(B)]
	5.6.11	<b>Mercury Limits and Monitoring Requirements.</b> [Minn. R. 7001]
	5.6.12	The Permittee is required to sample for total suspended solids (mercury grab sample) at the same time that total mercury and dissolved mercury samples are taken. [Minn. R. 7001]
	5.6.13	Total and dissolved mercury samples shall be grab samples and shall be analyzed using the most recent revisions of EPA Methods 1631 and 1669.  The Permittee is authorized to use another mercury analytical method that has a reportable level of <0.5 ng/L which allows for low-level sample characterization as long as the method is approved by the EPA and certified by an MPCA accreditation body. [Minn. R. 7001]
	5.6.14	Effluent monitoring for mercury with a frequency of twice per month and an effective period of Jan, Mar, May, Jul, Sep, Nov are to be taken twice per month during the months of January, March, May, July, September, and November. [Minn. R. 7001]
	5.6.15	<b>Nitrogen Limits and Monitoring Requirements.</b> [Minn. R. 7001]

5.6.16	"Total Nitrogen" with a sample type of "Calculation" is to be reported as the summation of the total Kjeldahl nitrogen and total nitrite plus nitrate nitrogen values. [Minn. R. 7001]
5.6.17	<b>Nitrogen Reduction Strategy Optimization Incentive (Voluntary).</b> [Minn. R. 7001]
5.6.18	<p>A 10 mg/L total nitrogen State Discharge Restriction (SDR) is being proposed for all major municipal wastewater treatment facilities, high concentration minor municipal wastewater treatment facilities, and high concentration industrial dischargers in a MPCA nitrate rulemaking effort. To encourage wastewater treatment facilities to start making achievable nitrogen reductions as soon as possible, the MPCA is proposing in the rulemaking to defer applicability of the SDR limit for one permit cycle for Permittees that have optimized their existing wastewater treatment operations and are able to meet a 15 mg/L total nitrogen limit based on a 12-Month Moving Average for at least 12 months prior to the adoption of a SDR.</p> <p>Note the following:</p> <p>A. The proposed SDR limit is applicable for all major municipal, high concentration minor municipal, and high concentration industrial dischargers. If the Permittee is not currently classified as a major facility but may be prior to SDR adoption, the Permittee may still have the opportunity to participate in this optimization incentive.</p> <p>B. This optimization incentive is dependent on successful rulemaking efforts. If the entire rulemaking or the optimization incentive-portion of the rulemaking are not successful, the SDR limit deferral will not be applicable.</p> <p>C. Once facilities have optimized to reduce their nitrogen concentrations, they must continue operating the facilities in accordance with the optimization efforts.</p> <p>Refer to the accompanying permit documents for additional information regarding the optimization incentive. [Minn. R. 7001]</p>
5.6.19	<b>Phosphorus Limit Types and Calculations.</b> [Minn. R. 7001]
5.6.20	<p>"12-Month Moving Total" is a rolling total. For the first 11 months after this limit becomes effective, report the mass phosphorus discharged by calculating each month's kg/month, then adding each month's kg/month from the first month the new limit is effective through the 11<sup>th</sup> month after this limit became effective. This value should be reported on the eDMR in the 12-Month Moving Total field.</p> <p>If using the eDMR calculator tool, replace the calculated value with the value calculated above as the eDMR calculated value will not be correct until 12 months of data are collected following permit reissuance. Starting the 12<sup>th</sup> month after this limit became effective and thereafter, calculate each kg/month then add all of the monthly values during the last twelve months, starting with the monthly total for the month of the current reporting period. Calculate kg/month for each month by multiplying the total volume of effluent flow (MG) x the monthly average concentration x 3.785 conversion factor to get kg/month. Starting the 12<sup>th</sup> month after this limit became effective and thereafter, the eDMR calculator tool will provide the correct value for this limit. [Minn. R. 7001]</p>
	<b>Waste Stream Station General Requirements</b>
5.7.24	<b>Sampling Collection and Reporting.</b> [Minn. R. 7001]
5.7.25	The Permittee shall submit monitoring results in accordance with the limits and monitoring requirements for this station. If conditions are such that no sample can be acquired, the Permittee shall report "No Flow" or "No Discharge" on Discharge Monitoring Report (DMR) and shall add a Comments attachment to the DMR detailing why the sample was not collected. [Minn. R. 7001.0150, Subp 2(B)]
5.7.26	<b>Mercury Limits and Monitoring Requirements.</b> [Minn. R. 7001]

5.7.27	<p>Total mercury samples shall be grab samples and shall be analyzed using the most recent revisions of EPA Methods 1631 and 1669.</p> <p>The Permittee is authorized to use another mercury analytical method that has a reportable level that allows for low-level sample characterization as long as the method is approved by the EPA and certified by a MPCA accreditation body. [Minn. R. 7001]</p>
5.7.28	<p>Influent samples for mercury monitoring with a frequency of twice per month and an effective period of Jan, Mar, May, Jul, Sep, Nov are to be taken at a time similar to that of effluent monitoring, if possible; twice per month during the months of January, March, May, July, September, and November. [Minn. R. 7001]</p>
5.7.29	<p><b>Nitrogen Limits and Monitoring Requirements.</b> [Minn. R. 7001]</p>
5.7.30	<p>"Total Nitrogen" with a sample type of "Calculation" is to be reported as the summation of the total Kjeldahl nitrogen and total nitrite plus nitrate nitrogen values. [Minn. R. 7001]</p>
	<p><b>Mechanical System</b></p>
5.8.34	<p><b>Bypass Structures.</b> [Minn. R. 7001]</p>
5.8.35	<p>All structures capable of bypassing the treatment system shall be manually controlled and kept locked at all times. [Minn. R. 7001.0030]</p>
5.8.36	<p><b>Sanitary Sewer Extension Permit.</b> [Minn. R. 7001]</p>
5.8.37	<p>The Permittee may be required to obtain a sanitary sewer extension permit from the MPCA for any addition, extension, or replacement to the sanitary sewer. If a sanitary sewer extension permit is required, construction may not begin until plans and specifications have been submitted and a written permit is granted except as allowed in Minn. Stat. 115.07, subd. 3b. [Minn. R. 7001.0020]</p>
5.8.38	<p><b>Operator Certification.</b> [Minn. R. 7001]</p>
5.8.39	<p>The Permittee shall provide a Class A state certified operator who maintains direct responsibility of the operation, maintenance, and testing functions required to ensure compliance with the terms and conditions of this permit. [Minn. R. 9400]</p>
5.8.40	<p>The Permittee shall provide the appropriate number of operators with a Type IV certification to be responsible for the land application of biosolids or semisolids from commercial or industrial operations. [Minn. R. 7048]</p>
5.8.41	<p>If the Permittee chooses to meet operator certification requirements through a contractual agreement, the Permittee shall provide a copy of the contract to the MPCA, WQ Submittals Center. The contract shall include:</p> <ul style="list-style-type: none"> <li>A. The certified operator's name, certificate number, company name (if appropriate), and the period covered by the contract and provisions for renewal;</li> <li>B. The duties and responsibilities of the certified operator;</li> <li>C. The duties and responsibilities of the Permittee; and</li> <li>D. Provisions for notifying the MPCA 30 days in advance of termination if the contract is terminated prior to the expiration date. [Minn. R. 9400]</li> </ul>
5.8.42	<p>The Permittee shall notify the MPCA within 30 days of a change in operator certification or contract status. [Minn. R. 9400]</p>
	<p><b>Pretreatment: Nondelegated Requirements</b></p>
5.9.45	<p><b>Definitions.</b> [Minn. R. 7049]</p>
5.9.46	<p>"Individual Control Mechanism" means a document, such as an agreement or permit, which imposes limitations or requirements on an individual industrial user of the publicly owned treatment works (POTW). [Minn. R. 7049]</p>

5.9.47	<p>"Significant Industrial User" (SIU) means any industrial user that:</p> <p>A. Is subject to Categorical Pretreatment Standards, as defined in Minn. R. 7049.0120, subp. 5;</p> <p>B. Discharges 25,000 gallons per day or more of process wastewater, excluding sanitary, noncontact cooling, or boiler blowdown wastewater, to the POTW;</p> <p>C. Contributes a process wastewater containing five percent or more of the flow or load of any pollutant of concern to the POTW; or</p> <p>D. Is designated as significant by the Permittee or the MPCA on the basis that the industrial user has a reasonable potential to adversely impact the POTW's operation or violate any pretreatment standard or requirement. [Minn. R. 7049]</p>
5.9.48	<p><b>Permittee Responsibility to Control Users.</b> [Minn. R. 7049]</p>
5.9.49	<p>It is the Permittee's responsibility to regulate the discharge from users of its POTW. The Permittee shall prevent any pass through of pollutants or any inhibition or disruption of the Permittee's POTW, its treatment processes, or its sludge processes or disposal that contribute to the violation of the conditions of this permit or any federal or state law or regulation limiting the release of pollutants from the POTW. [Minn. R. 7049]</p>
5.9.50	<p>The Permittee shall prohibit the discharge of the following to its POTW:</p> <p>A. Pollutants that create a fire or explosion hazard, including any discharge with a flash point less than 60 degrees C (140 degrees F);</p> <p>B. Pollutants that will cause corrosive structural damage to the POTW, including any waste stream with a pH of less than 5.0;</p> <p>C. Solid or viscous pollutants which would obstruct flow;</p> <p>D. Any pollutant, including oxygen-demanding pollutants such as biochemical oxygen demand, released at a flow rate or pollutant concentration that will cause interference or pass-through;</p> <p>E. Heat that would inhibit biological activity, including any discharge that would cause the temperature of the waste stream at the POTW treatment plant headwork's to exceed 40 degrees C (104 degrees F);</p> <p>F. Petroleum oil, nonbiodegradable cutting oil, or products of mineral oil origin in amounts that would cause interference or pass-through; and</p> <p>G. Pollutants that produce toxic gases, vapors, or fumes that may endanger the health or safety of workers. [Minn. R. 7049]</p>
5.9.51	<p>The Permittee shall prohibit new discharges of non-contact cooling waters unless there is no cost effective alternative. Existing discharges of non-contact cooling water to the Permittee's POTW shall be eliminated, where elimination is cost effective, or where an infiltration/inflow analysis and sewer system evaluation survey indicates the need for such removal. [Minn. R. 7049]</p>
5.9.52	<p>If the Permittee accepts trucked-in wastes, the Permittee shall evaluate the trucked-in wastes prior to acceptance in the same manner as it monitors sewered wastes. The Permittee shall accept trucked-in wastes only at specifically designated points. [Minn. R. 7049]</p>
5.9.53	<p>Pollutant of concern means a pollutant that is or may be discharged by an industrial user that is or reasonably should be of concern on the basis that it may cause the Permittee to violate any permit limits on the release of pollutants. The following pollutants shall be evaluated to determine if they should be pollutants of concern:</p> <p>A. Pollutants limited in this permit;</p> <p>B. Pollutants for which monitoring is required in this permit;</p> <p>C. Pollutants that are likely to cause inhibition of the Permittee's POTW;</p> <p>D. Pollutants which may interfere with sludge disposal; and</p> <p>E. Pollutants for which the Permittee's POTW has limited capacity. [Minn. R. 7049]</p>
5.9.54	<p><b>Control of Significant Industrial Users.</b> [Minn. R. 7049]</p>
5.9.55	<p>The Permittee shall impose pretreatment requirements on SIUs to ensure compliance with all applicable effluent limitations and other requirements set forth in this permit or any federal or state law or regulation limiting the release of pollutants from the POTW. These requirements shall be applied to SIUs by means of an individual control mechanism. [Minn. R. 7049]</p>

5.9.56	The Permittee shall not knowingly enter into an individual control mechanism with any user that would allow the user to contribute an amount or strength of wastewater that would cause violation of any limitation or requirement in the permit, or any applicable federal, state, or local law or regulation. [Minn. R. 7049]
5.9.57	<b>Monitoring of Significant Industrial Users.</b> [Minn. R. 7049]
5.9.58	The Permittee shall obtain specific information from SIUs on the quality and quantity of the SIU's discharges to the Permittee's POTW. Except where specifically requested by the Permittee and approved by the MPCA, this information shall be obtained by means of representative monitoring conducted by the Permittee or by the SIU under requirements imposed by the Permittee in the SIU's individual control mechanism. Monitoring performed to comply with this requirement shall include all pollutants for which the SIU is significant and shall be done at a frequency commensurate with the significance of the SIU. [Minn. R. 7049]
5.9.59	<b>Reporting and Notifications.</b> [Minn. R. 7049]
5.9.60	The Permittee shall submit a Pretreatment Annual Report: due by 31 days after the end of each calendar year following permit issuance if a SIU discharges to the POTW during a given calendar year. [Minn. R. 7049]
5.9.61	The Permittee shall submit the Pretreatment Annual Report found on the MPCA's website at <a href="https://www.pca.state.mn.us/business-with-us/wastewater-pretreatment">https://www.pca.state.mn.us/business-with-us/wastewater-pretreatment</a> or shall provide equivalent information. [Minn. R. 7049]
5.9.62	The Permittee shall submit the Pretreatment Annual Report to the MPCA, WQ Submittals Center. [Minn. R. 7049]
5.9.63	<p>The Permittee shall notify the MPCA in writing of any of the following:</p> <ul style="list-style-type: none"> <li>A. Any SIU of the Permittee's POTW which has not been previously disclosed to the MPCA;</li> <li>B. Anticipated or actual changes in the volume or quality of discharge by an industrial user that could result in the industrial user becoming an SIU as defined in this section; or</li> <li>C. Anticipated or actual changes in the volume or quality of discharges by a SIU that would require changes to the SIU's required local limits.</li> </ul> <p>This notification shall be submitted within 30 days of identifying the industrial user as a SIU. Where changes are proposed, they shall be submitted prior to changes being made. [Minn. R. 7049]</p>
5.9.64	<p>Upon notifying the MPCA of a SIU or change in a SIU discharge as required above, the Permittee shall submit the following information using the forms found on the MPCA's website at <a href="https://www.pca.state.mn.us/water/wastewater-pretreatment">https://www.pca.state.mn.us/water/wastewater-pretreatment</a> or in a comparable format:</p> <ul style="list-style-type: none"> <li>A. The identity of the SIU and a description of the SIU's operation and process;</li> <li>B. A characterization of the SIU's discharge;</li> <li>C. The required local limits that will be imposed on the SIU;</li> <li>D. A technical justification of the required local limits; and</li> <li>E. A plan for monitoring the SIU which is consistent with monitoring requirements in this section.</li> </ul> <p>[Minn. R. 7049]</p>
5.9.65	<p>In addition, the Permittee shall, upon request, submit the following to the MPCA for approval:</p> <ul style="list-style-type: none"> <li>A. Additional information on the SIU, its processes, and discharge;</li> <li>B. A copy of the individual control mechanism used to control the SIU;</li> <li>C. The Permittee's legal authority to be used for regulating the SIU; and</li> <li>D. The Permittee's procedures for enforcing the requirements imposed on the SIU. [Minn. R. 7049]</li> </ul>
5.9.66	The Permittee shall notify the MPCA of any of its industrial users that may be subject to National Categorical Pretreatment Standards. [Minn. R. 7049]
5.9.67	This permit may be modified in accordance with Minn. R. ch. 7001 to require development of a pretreatment program approvable under the Federal General Pretreatment Regulation (40 CFR 403). [Minn. R. 7049]

	<b>Biosolids: Land Application</b>																																				
<b>5.10.68</b>	<b>Authorization.</b> [Minn. R. 7041]																																				
<b>5.10.69</b>	This permit authorizes the Permittee to store and land apply domestic wastewater treatment biosolids in accordance with the provisions in this section and Minn. R. ch. 7041. [Minn. R. 7041]																																				
<b>5.10.70</b>	Permittees who prepare bulk biosolids shall obtain approval of the sites on which bulk biosolids are applied before they are applied unless they are Exceptional Quality Biosolids. Site application procedures are set forth in Minn. R. 7041.0800. [Minn. R. 7041.0600, Minn. R. 7041.0800]																																				
<b>5.10.71</b>	<b>Compliance Responsibility.</b> [Minn. R. 7041]																																				
<b>5.10.72</b>	The Permittee is responsible for ensuring that the applicable requirements in this section and Minn. R. ch. 7041 are met when biosolids are prepared, distributed, and/or applied to the land. [Minn. R. 7041]																																				
<b>5.10.73</b>	<b>Notification Requirements.</b> [Minn. R. 7041]																																				
<b>5.10.74</b>	The Permittee shall provide information needed to comply with the biosolids requirements of Minn. R. ch. 7041 to others who prepare or use the biosolids. [Minn. R. 7041]																																				
<b>5.10.75</b>	<b>Pollutant Limits.</b> [Minn. R. 7041]																																				
<b>5.10.76</b>	<p>Biosolids which are applied to the land shall not exceed the ceiling concentrations in Table 1 and shall not be applied so that the cumulative amounts of pollutant in Table 2 are exceeded.</p> <p>Table 1 Ceiling Concentrations (dry weight basis)            Parameter in units mg/kg</p> <table border="0"> <tr><td>Arsenic</td><td>75</td></tr> <tr><td>Cadmium</td><td>85</td></tr> <tr><td>Copper</td><td>4300</td></tr> <tr><td>Lead</td><td>840</td></tr> <tr><td>Mercury</td><td>57</td></tr> <tr><td>Molybdenum</td><td>75</td></tr> <tr><td>Nickel</td><td>420</td></tr> <tr><td>Selenium</td><td>100</td></tr> <tr><td>Zinc</td><td>7500</td></tr> </table> <p>Table 2 Cumulative Loading Limits            Parameter in units lbs/acre</p> <table border="0"> <tr><td>Arsenic</td><td>37</td></tr> <tr><td>Cadmium</td><td>35</td></tr> <tr><td>Copper</td><td>1339</td></tr> <tr><td>Lead</td><td>268</td></tr> <tr><td>Mercury</td><td>15</td></tr> <tr><td>Molybdenum</td><td>not established*</td></tr> <tr><td>Nickel</td><td>375</td></tr> <tr><td>Selenium</td><td>89</td></tr> <tr><td>Zinc</td><td>2500</td></tr> </table> <p>*The cumulative limit for molybdenum has not been established at the time of permit issuance.            [Minn. R. 7041.1100]</p>	Arsenic	75	Cadmium	85	Copper	4300	Lead	840	Mercury	57	Molybdenum	75	Nickel	420	Selenium	100	Zinc	7500	Arsenic	37	Cadmium	35	Copper	1339	Lead	268	Mercury	15	Molybdenum	not established*	Nickel	375	Selenium	89	Zinc	2500
Arsenic	75																																				
Cadmium	85																																				
Copper	4300																																				
Lead	840																																				
Mercury	57																																				
Molybdenum	75																																				
Nickel	420																																				
Selenium	100																																				
Zinc	7500																																				
Arsenic	37																																				
Cadmium	35																																				
Copper	1339																																				
Lead	268																																				
Mercury	15																																				
Molybdenum	not established*																																				
Nickel	375																																				
Selenium	89																																				
Zinc	2500																																				
<b>5.10.77</b>	<b>Pathogen and Vector Attraction Reduction.</b> [Minn. R. 7041]																																				
<b>5.10.78</b>	Biosolids shall be processed, treated, or be incorporated or injected into the soil to meet one of the vector attraction reduction requirements in Minn. R. 7041.1400. [Minn. R. 7041.1400]																																				
<b>5.10.79</b>	Biosolids shall be processed or treated by one of the alternatives in Minn. R. 7041.1300 to meet the Class A or Class B standards for the reduction of pathogens. When Class B biosolids are applied to the land, the site restrictions in Minn. R. 7041.1300 shall also be met. [Minn. R. 7041.1300]																																				

5.10.80	<p>The minimum duration between application and harvest, grazing, or public access to areas where Class B biosolids have been applied to the land is as follows:</p> <p>A. 14 months for food crops whose harvested parts may touch the soil/biosolids mixture (such as melons, squash, tomatoes, etc.), when biosolids are surface applied, incorporated, or injected;                  B. 20 months or 38 months depending on the application method for food crops whose harvested parts grow in the soil (such as potatoes, carrots, onions, etc). The 20-month time period is required when biosolids are surface applied or surface applied and incorporated after they have been on the soil surface for at least four months. The 38-month time period is required when the biosolids are injected or surface applied and incorporated within four months of application;                  C. 30 days for feed crops, other food crops (such as field corn, sweet corn, etc.), hay, or fiber crops when biosolids are surface applied, incorporated, or injected;                  D. 30 days for grazing of animals when biosolids are surface applied, incorporated, or injected; and                  E. One year where there is a high potential for public contact with the site (such as a reclamation site located in populated areas, a construction site located in a city, turf farms, plant nurseries, etc.) and 30 days where there is low potential for public contact (such as agricultural land, forest, a reclamation site located in an unpopulated area, etc.) when biosolids are surface applied, incorporated, or injected. [Minn. R. 7041]</p>																		
5.10.81	<p><b>Management Practices.</b> [Minn. R. 7041]</p>																		
5.10.82	<p>The management practices for the land application of biosolids are described in detail in Minn. R. 7041.1200 and shall be followed unless specified otherwise in a site approval letter or a permit issued by the MPCA. [Minn. R. 7041]</p>																		
5.10.83	<p>Overall management requirements:</p> <p>A. Biosolids shall not be applied to the land if it is likely to adversely affect a threatened or endangered species listed under Section 4 of the Endangered Species Act or its designated critical habitat;                  B. Biosolids shall not be applied to flooded, frozen, or snow covered ground so that the biosolids enter wetlands or other waters of the state;                  C. Biosolids shall be applied at an agronomic rate unless specified otherwise by the MPCA in a permit; and                  D. Biosolids shall not be applied within 33 feet of a wetland or waters of the state unless specified otherwise by the MPCA in a permit. [Minn. R. 7041]</p>																		
5.10.84	<p><b>Monitoring Requirements.</b> [Minn. R. 7041]</p>																		
5.10.85	<p>Representative samples of biosolids applied to the land shall be analyzed by methods specified in Minn. R. 7041.3200 for the following parameters: arsenic, cadmium, copper, lead, mercury, molybdenum, nickel, selenium, zinc, Kjeldahl nitrogen, ammonia nitrogen, total solids, volatile solids, phosphorus, potassium, and pH. [Minn. R. 7041.3200]</p>																		
5.10.86	<p>At a minimum, biosolids shall be monitored at the frequencies specified in Table 3 for the parameters listed above, and any pathogen or vector attraction reduction requirements in Minn. R. 7041.1300 and 7041.1400 if used to determine compliance with those parts.</p> <table border="1" data-bbox="423 1612 1554 1871"> <thead> <tr> <th colspan="3">Table 3 Minimum Sampling Frequencies</th> </tr> <tr> <th>Biosolids Applied* (metric tons/365-day period)</th> <th>Biosolids Applied* (tons/365-day period)</th> <th>Frequency (times/365-day period)</th> </tr> </thead> <tbody> <tr> <td>&gt;0 but &lt;290</td> <td>&gt;0 but &lt;320</td> <td>1</td> </tr> <tr> <td>&gt;=290 but &lt;1,500</td> <td>&gt;=320 but &lt;1,650</td> <td>4</td> </tr> <tr> <td>&gt;=1,500 but &lt;15,000</td> <td>&gt;=1,650 but &lt;16,500</td> <td>6</td> </tr> <tr> <td>&gt;=15,000</td> <td>&gt;=16,500</td> <td>12</td> </tr> </tbody> </table> <p>*Either the amount of bulk biosolids applied to the land or the amount of biosolids received by a person who prepares biosolids that are sold or given away in a bag or other container for application to the land (dry weight basis). [Minn. R. 7041.1300]</p>	Table 3 Minimum Sampling Frequencies			Biosolids Applied* (metric tons/365-day period)	Biosolids Applied* (tons/365-day period)	Frequency (times/365-day period)	>0 but <290	>0 but <320	1	>=290 but <1,500	>=320 but <1,650	4	>=1,500 but <15,000	>=1,650 but <16,500	6	>=15,000	>=16,500	12
Table 3 Minimum Sampling Frequencies																			
Biosolids Applied* (metric tons/365-day period)	Biosolids Applied* (tons/365-day period)	Frequency (times/365-day period)																	
>0 but <290	>0 but <320	1																	
>=290 but <1,500	>=320 but <1,650	4																	
>=1,500 but <15,000	>=1,650 but <16,500	6																	
>=15,000	>=16,500	12																	

5.10.87	<p>Representative samples of biosolids that are transferred to storage units and are stored for more than two years shall be analyzed by methods specified in Minn. R. 7041.3200 for each cropping year they are stored for the following parameters: arsenic, cadmium, copper, lead, molybdenum, nickel, selenium, and zinc.</p> <p>Mercury is specifically NOT included in the stored biosolids analysis because of the short holding time (28 days) required between sampling and analysis. [Minn. R. 7041.1300, Minn. R. 7041.3200]</p>																				
5.10.88	<p>Increased sampling frequencies are specified for the parameters listed in Table 4. Sampling at a frequency at twice the minimum frequencies in Table 3 is required if concentrations listed in Table 4 are exceeded (based on the average of all analyses made during the previous cropping year).</p> <p>Table 4 Increased Frequency of Sampling</p> <table border="0" data-bbox="423 667 813 989"> <tr> <td colspan="2">Parameter (mg/kg dry weight basis)</td> </tr> <tr> <td>Arsenic</td> <td>38</td> </tr> <tr> <td>Cadmium</td> <td>43</td> </tr> <tr> <td>Copper</td> <td>2150</td> </tr> <tr> <td>Lead</td> <td>420</td> </tr> <tr> <td>Mercury</td> <td>28</td> </tr> <tr> <td>Molybdenum</td> <td>38</td> </tr> <tr> <td>Nickel</td> <td>210</td> </tr> <tr> <td>Selenium</td> <td>50</td> </tr> <tr> <td>Zinc</td> <td>3750. [Minn. R. 7041]</td> </tr> </table>	Parameter (mg/kg dry weight basis)		Arsenic	38	Cadmium	43	Copper	2150	Lead	420	Mercury	28	Molybdenum	38	Nickel	210	Selenium	50	Zinc	3750. [Minn. R. 7041]
Parameter (mg/kg dry weight basis)																					
Arsenic	38																				
Cadmium	43																				
Copper	2150																				
Lead	420																				
Mercury	28																				
Molybdenum	38																				
Nickel	210																				
Selenium	50																				
Zinc	3750. [Minn. R. 7041]																				
5.10.89	<p><b>Records.</b> [Minn. R. 7041]</p>																				
5.10.90	<p>The Permittee shall keep records of the information necessary to show compliance with pollutant concentrations and loadings, pathogen reduction requirements, vector attraction reduction requirements, and management practices as specified in Minn. R. 7041.1600, as applicable to the quality of biosolids produced. [Minn. R. 7041.1600]</p>																				
5.10.91	<p><b>Reporting Requirements.</b> [Minn. R. 7041]</p>																				
5.10.92	<p>The Permittee shall submit a Biosolids Annual Report: due annually, by the 31st of December. [Minn. R. 7041.1700]</p>																				
5.10.93	<p>The Permittee shall submit the Biosolids Annual Report found on the MPCA's website at <a href="https://www.pca.state.mn.us/business-with-us/wastewater-operator-resources">https://www.pca.state.mn.us/business-with-us/wastewater-operator-resources</a> or shall provide equivalent information in another MPCA approved format. The report shall include the requirements in Minn. R. 7041.1700. [Minn. R. 7041.1700]</p>																				
5.10.94	<p>The Biosolids Annual Report shall be submitted by December 31 of each year for biosolids storage and/or transfer activities occurring during the cropping year previous to December 31.</p> <p>Cropping year means a year beginning on September 1 of the year prior to the growing season and ending August 31 the year the crop is harvested. For example, the 2019 cropping year began September 1, 2018 and ended August 31, 2019. [Minn. R. 7041]</p>																				
5.10.95	<p>The Biosolids Annual Report shall indicate whether or not biosolids were transferred and/or stored. If biosolids were transferred, the report shall describe:</p> <ul style="list-style-type: none"> <li>A. How much was transferred;</li> <li>B. Where it was transferred to;</li> <li>C. The name of the facility that accepted the transfer; and</li> <li>D. The contact person at that facility. [Minn. R. 7041]</li> </ul>																				
5.10.96	<p>For biosolids that are stored for more than two years, the Biosolids Annual Report shall also include the analytical data from the representative sample of the biosolids generated during the cropping year. [Minn. R. 7041]</p>																				
5.10.97	<p>The Permittee shall submit the Biosolids Annual Report to the MPCA, WQ Submittals Center. [Minn. R. 7041]</p>																				

5.10.98	The Permittee shall notify the MPCA in writing when 90 percent or more of any of the cumulative pollutant loading rates listed for any land application sites has been reached for a site. [Minn. R. 7041]
	<b>Total Residual Oxidants</b>
5.11.99	<b>General Requirements.</b> [Minn. R. 7001]
5.11.100	Total Residual Chlorine (TRC) shall be analyzed immediately. This means within 15 minutes or less of sample collection. [40 CFR 136.6]
5.11.101	A Reporting Limit (RL) shall be established for this parameter. This must be based on the analysis of a standard at or below the RL. [Minn. R. 7001]
5.11.102	A RL of 0.04 mg/L is considered in compliance with the 0.038 mg/L limit. [Minn. R. 7001]
5.11.103	The RL shall be verified against a known standard at least monthly during the monitoring period. For successful verification, the standard needs to be recovered at +/- 40% of the actual value. [Minn. R. 7001]
5.11.104	Monitoring results below the RL should be reported as "<" the RL. If the RL is 0.01 mg/L, based on the analysis of a standard at or below that level, and a parameter is not detected at a value of 0.01 mg/L or greater, the concentration shall be reported as "<0.01 mg/L." The symbol "<" means "less than." [Minn. R. 7001]
5.11.105	<b>Compliance with a Daily Maximum Limit.</b> [Minn. R. 7001]
5.11.106	Compliance with a Daily Maximum limit for Total Residual Chlorine (TRC) concentration limits can be evaluated using one of the two following methods. [State Definitions]
5.11.107	Single Sample Value - A single sample taken in a 24-hour period with a value of 0.038 mg/L or less is considered in compliance; or. [Minn. R. 7001]
5.11.108	Multiple Sample Value - If the single value sample is greater than 0.038 mg/L, an average can be calculated using two to twelve samples analyzed in a 24-hour period. To calculate using multiple samples: A. The second sample shall be taken two hours after the initial sample; and B. Subsequent samples shall be taken at one-hour intervals not to exceed twelve samples in a 24-hour period  The average value of the multiple samples must be 0.038 mg/L or less to be considered in compliance. Values below the RL for TRC are assumed to be zero for averaging purposes only. [Minn. R. 7001]
	<b>Total Facility Requirements (NPDES/SDS)</b>
5.12.112	<b>Definitions.</b> Refer to the Permit User's Manual found on the MPCA's website at <a href="https://www.pca.state.mn.us/sites/default/files/wq-wwtp7-09.pdf">https://www.pca.state.mn.us/sites/default/files/wq-wwtp7-09.pdf</a> for standard definitions. [Minn. R. 7001]
5.12.113	<b>Incorporation by Reference.</b> This permit incorporates the following applicable federal and state laws as enforceable parts of this permit: 40 CFR pts. 122.41, 122.42, 136, 403 and 503; Minn. R. chs. 7001, 7041, 7045, 7050, 7052, 7053, 7060, and 7080; and Minn. Stat. chs. 115 and 116. [Minn. R. 7001]
5.12.114	<b>Permittee Responsibility.</b> The Permittee shall perform the actions or conduct the activities authorized by this permit in compliance with the conditions of the permit and, if required, in accordance with the plans and specifications approved by the MPCA. [Minn. R. 7001.0150, subp. 3(E)]
5.12.115	<b>Toxic Discharges Prohibited.</b> Whether or not this permit includes effluent limitations for toxic pollutants, the Permittee shall not discharge a toxic pollutant except according to 40 CFR pts. 400 to 460; Minn. R. chs. 7050, 7052, and 7053; and any other applicable MPCA rules. [Minn. R. 7001.1090, subp. 1(A)]

5.12.116	<b>Nuisance Conditions Prohibited.</b> The Permittee's discharge shall not cause any nuisance conditions including, but not limited to: floating solids, scum and visible oil film, excessive suspended solids, material discoloration, obnoxious odors, gas ebullition, deleterious sludge deposits, undesirable slimes or fungus growths, aquatic habitat degradation, excessive growths of aquatic plants, acutely toxic conditions to aquatic life, or other adverse impact on the receiving water. The discharge shall not cause a material discoloration in the receiving water. Any discharge that results in a discernable change to the existing/ambient color of the receiving water constitutes material discoloration. [Minn. R. 7050.0210, subp. 2]
5.12.117	<b>Property Rights.</b> This permit does not convey a property right or an exclusive privilege. [Minn. R. 7001.0150, subp. 3(C)]
5.12.118	<b>Liability Exemption.</b> In issuing this permit, the State and the MPCA assume no responsibility for damage to persons, property, or the environment caused by the activities of the Permittee in the conduct of its actions, including those activities authorized, directed, or undertaken under this permit. To the extent the State and the MPCA may be liable for the activities of its employees, that liability is explicitly limited to that provided in the Tort Claims Act. [Minn. R. 7001.0150, subp. 3(O)]
5.12.119	The MPCA's issuance of this permit does not obligate the MPCA to enforce local laws, rules, or plans beyond what Minnesota statutes authorize. [Minn. R. 7001.0150, subp. 3(D)]
5.12.120	<b>Liabilities.</b> The MPCA's issuance of this permit does not release the Permittee from any liability, penalty, or duty imposed by Minnesota or federal statutes or rules or local ordinances, except the obligation to obtain the permit. [Minn. R. 7001.0150, subp. 3(A)]
5.12.121	The issuance of this permit does not prevent the future adoption by the MPCA of pollution control rules, standards, or orders more stringent than those now in existence and does not prevent the enforcement of these rules, standards, or orders against the Permittee. [Minn. R. 7001.0150, subp. 3(B)]
5.12.122	<b>Severability.</b> The provisions of this permit are severable and, if any provisions of this permit or the application of any provision of this permit to any circumstance are held invalid, the application of such provision to other circumstances and the remainder of this permit shall not be affected thereby. [Minn. R. 7001]
5.12.123	<b>Compliance with Other Rules and Statutes.</b> The Permittee shall comply with all applicable air quality, solid waste, and hazardous waste statutes and rules in the operation and maintenance of the facility. [Minn. R. 7001]
5.12.124	<b>Inspection and Entry.</b> When authorized by Minn. Stat. ch. 115.04, 115B.17, subd. 4, and 116.091, and upon presentation of proper credentials, the Permittee shall allow the MPCA, or an authorized employee or agent of the MPCA, to enter at reasonable times upon the property of the Permittee to examine and copy books, papers, records, or memoranda pertaining to the construction, modification, or operation of the facility covered by the permit or pertaining to the activity covered by the permit; and to conduct surveys and investigations, including sampling, monitoring, and other inspection equipment, pertaining to the construction, modification, or operation of the facility covered by the permit or pertaining to the activities covered by the permit. [Minn. R. 7001.0150, subp. 3(I)]
5.12.125	<b>Control Users.</b> The Permittee shall regulate the users of its facility to prevent the introduction of pollutants or materials that may result in the inhibition or disruption of the conveyance system, treatment facility or processes, or disposal system that would contribute to the violation of the conditions of this permit or any federal, state, or local law or regulation. [Minn. R. 7001.0150, subp. 3(F)]
5.12.126	<b>Sampling.</b> [Minn. R. 7001]
5.12.127	<b>Representative Sampling.</b> Sampling and measurements required by the permit shall be conducted as specified in the permit and shall be representative of the discharge or monitored activities. [Minn. R. 7001.0150, subp. 2(B)]
5.12.128	<b>Additional Sampling.</b> If the Permittee monitors more frequently than required, they shall report the results and the frequency of monitoring on their eDMR for that reporting period. [Minn. R. 7001.1090, subp. 1(E)]

5.12.129	<b>Certified/Accredited Laboratory.</b> A laboratory accredited by the Minnesota Department of Health [Minn. R. 4740.2010 through Minn. R. 4740.2120] and/or certified by the MPCA [Minn. R. 7001.4310 through Minn. R. 7001.4390] shall conduct analyses required by this permit, unless approved in writing by the MPCA. A certified/accredited laboratory does not need to complete analyses of dissolved oxygen, pH, temperature, specific conductance, and total residual oxidants (chlorine, bromine). Those analyses shall comply with 40 CFR pt. 136, including calibrations and the QA/QC section. Dissolved oxygen, pH, and total residual oxidants must be performed on-site. Follow the manufacturer's specifications for equipment maintenance and use. [Minn. R. 4740.2010-4740.2120, Minn. R. 7001.4310-7001.4390]
5.12.130	<b>Sample Preservation and Procedure.</b> Sample preservation and test procedures for the analysis of pollutants shall conform to 40 CFR pt. 136, including calibrations, the QA/QC section, and Minn. R. 7041.3200. Note - Table II of 40 CFR pt. 136.3 contains the requisite sample container, preservation (including, but not limited to thermal and pH adjustment), and holding times. [Minn. R. 7001.0150, subp. 2(B), Minn. R. 7041.3200]
5.12.131	<b>Equipment Calibration.</b> The Permittee shall check and/or calibrate flow meters, pumps, flumes, lift stations, or other flow monitoring equipment used for purposes of determining compliance (within plus or minus ten percent of the true flow values) with permit requirements at least twice annually. [Minn. R. 7001.0150, subp. 2(B & C)]
5.12.132	<b>Maintain Records.</b> The Permittee shall keep the records required by this permit for at least three years, including any calculations, original recordings from automatic monitoring instruments, and laboratory sheets. The Permittee shall extend these record retention periods upon request of the MPCA. The Permittee shall maintain records for each sample and measurement. The records shall include the following information: A. The exact place, date, and time of the sample or measurement; B. The date and time of analysis; C. The name of the person who performed the sample collection, measurement, analysis, or calculation; D. The analytical techniques, procedures, and methods used; and E. The results of the analysis. [Minn. R. 7001.0150, subp. 2(C)]
5.12.133	<b>Completing Reports.</b> The Permittee shall submit the results of the required sampling and monitoring activities on the forms provided, specified, or approved by the MPCA or as stipulated elsewhere in this permit. The Permittee shall record the information in the specified areas on those forms and in the units specified.  Required forms may include a Sample Values Form. If required, the Permittee shall record individual values for each sample and measurement on the Sample Values Form provided by the MPCA. The Permittee shall submit the Sample Values Form with the appropriate eDMRs. The Permittee may design and use their own Sample Values Form after MPCA review and approval.  Note: The Permittee shall also record required summary information on their eDMR. Permittee submitted summary information contained only on the Sample Values Form does not comply with reporting requirements. [Minn. R. 7001.0150, subp. 2(B), Minn. R. 7001.1090, subp. 1(D)]

<b>5.12.134</b>	<p><b>Submitting Reports.</b> The Permittee shall submit eDMRs, Sample Values Forms, and other supplemental attachment forms via MPCA e-Services after the MPCA approves their authorization request.</p> <p>The Permittee shall electronically submit eDMRs, Sample Values Forms, and other supplemental attachment forms by the 21st day of the month following the sampling period or otherwise as specified in this permit. The Permittee shall complete eDMR submittal on or before 11:59 p.m. of the 21st day of the month following the sampling period or as otherwise specified in this permit. The Permittee shall submit an eDMR for each required station even if no discharge occurred during the reporting period.</p> <p>The Permittee shall submit other reports required by this permit electronically. The Permittee shall submit reports by the date specified in this permit. The Permittee shall submit reports on or before 11:59 p.m. on the date specified in this permit.</p> <p>Electronically: wq.submittals.mPCA@state.mn.us Include water quality submittals form: <a href="http://www.pca.state.mn.us/sites/default/files/wq-wwprm7-71.docx">www.pca.state.mn.us/sites/default/files/wq-wwprm7-71.docx</a>. [Minn. R. 7001.0150, subp. 2(B), Minn. R. 7001.0150, subp. 3(H)]</p>
<b>5.12.135</b>	<p><b>Incomplete or Incorrect Reports.</b> The Permittee shall immediately submit an electronically amended report or eDMR to the MPCA upon discovery by the Permittee or notification by the MPCA that it has submitted an incomplete or incorrect report or eDMR. The amended report or eDMR shall contain the missing or corrected data along with a comment on the eDMR explaining the circumstances of the incomplete or incorrect report. If it is impossible to amend the report or eDMR electronically, the Permittee shall immediately notify the MPCA and the MPCA will provide direction for the amendment submittals. [Minn. R. 7001.0150, subp. 3(G)]</p>
<b>5.12.136</b>	<p><b>Required Signatures.</b> The Permittee or the duly authorized representative of the Permittee shall sign all eDMRs, forms, reports, and other documents submitted to the MPCA per Minn. R. 7001.0150, subp. 2(D). The person or persons who sign the eDMRs, forms, reports, or other documents shall certify that he or she understands and complies with the certification requirements of Minn. R. chs. 7001.0070 and 7001.0540, including the penalties for submitting false information. A registered professional engineer shall certify technical documents, such as design drawings and specifications, and engineering studies submitted as part of a permit application or by permit conditions. [Minn. R. 7001.0540]</p>
<b>5.12.137</b>	<p><b>Reporting Limit (RL).</b> The Permittee shall report monitoring results below the RL of a particular instrument as "&lt;" the value of the RL. For example, if an instrument has a RL of 0.1 mg/L and a parameter is not detected at a value of 0.1 mg/L or greater, the Permittee shall report the concentration as "&lt; 0.1 mg/L." The Permittee shall not use "non-detected," "undetected," "below detection limit," or "zero" when reporting results. The MPCA considers these terms as permit reporting violations.</p> <p>Where sample values are less than the RL and the permit requires reporting of an average, the Permittee shall calculate the average as follows:</p> <ul style="list-style-type: none"><li>A. If some values are less than (&lt;) the RL, substitute zero for all non-detectable values to use in the average calculation;</li><li>B. If all values are less than (&lt;) the RL, calculate the average and report as &lt; the RL average concentration; and</li><li>C. To calculate a mass loading with a less than (&lt;) the RL concentration, use the RL value in the calculation and then add the "&lt;" to the product of the concentration and the volume. [Minn. R. 7001.0150, subp. 2(B)]</li></ul>
<b>5.12.138</b>	<p><b>Records.</b> The Permittee shall, when requested by the MPCA, submit within a reasonable time the information and reports that are relevant to the control of pollution regarding the construction, modification, or operation of the facility covered by the permit or regarding the conduct of the activities covered by the permit. [Minn. R. 7001.0150, subp. 3(H)]</p>

5.12.139	<b>Confidential Information.</b> Except for data determined to be confidential according to Minn. Stat. ch. 116.075, subd. 2, all reports required by this permit are available for public inspection. The MPCA does not consider effluent data confidential. To request the MPCA maintain data as confidential, the Permittee shall follow Minn. R. 7000.1300. [Minn. R. 7000.1300]
5.12.140	<b>Noncompliance and Enforcement.</b> [Minn. R. 7001]
5.12.141	<b>Subject to Enforcement Action and Penalties.</b> Noncompliance with a term or condition of this permit subjects the Permittee to penalties provided by federal and state law set forth in section 309 of the Clean Water Act; United States Code, title 33, section 1319, as amended; and in Minn. Stat. ch. 115.071 and 116.072, including monetary penalties, imprisonment, or both. [Minn. R. 7001.1090, subp. 1(B)]
5.12.142	<b>Criminal Activity.</b> The Permittee shall not knowingly make a false statement, representation, or certification in a record or other document submitted to the MPCA. A person who falsifies a report or document submitted to the MPCA, or tampers with, or knowingly renders inaccurate a monitoring device or method that requires maintenance under this permit is subject to criminal and civil penalties provided by federal and state law. [Minn. R. 7001.0150, subp. 3(G), Minn. R. 7001.1090, subp. 1(G & H), Minn. Stat. ch. 609.671, subd. 1]
5.12.143	<b>Noncompliance Defense.</b> It shall not be a defense for the Permittee in an enforcement action that it would have been necessary to halt or reduce the permitted activity in order to maintain compliance with the conditions of this permit. [40 CFR 122.41(c)]
5.12.144	<b>Effluent Violations.</b> If sampling by the Permittee indicates a violation of any discharge limitation specified in this permit, the Permittee shall immediately make every effort to verify the violation by collecting additional samples, if appropriate, investigate the cause of the violation, and take action to prevent future violations.  If the Permittee discovers that noncompliance with a condition of the permit occurred and that the noncompliance could endanger human health, public drinking water supplies, or the environment, the Permittee shall within 24 hours of the discovery of the noncompliance orally notify the Commissioner and submit a written description of the noncompliance within five days of the discovery.  If the Permittee discovers other noncompliance that does not explicitly endanger human health, public drinking water supplies, or the environment, the Permittee shall report the description of noncompliance within 30 days of the discovery. If no eDMR is required within 30 days, the Permittee shall submit a written report (see the Submitting Reports part of this chapter) including the description of noncompliance within 30 days of the discovery of the noncompliance. This description shall include the following information: A. A description of the event including volume, duration, monitoring results, and receiving waters; B. The cause of the event; C. The steps taken to reduce, eliminate, and prevent reoccurrence of the event; D. The exact dates and times of the event; and E. Steps taken to reduce any adverse impact resulting from the event. [Minn. R. 7001.0150, subp. 3(K)]

5.12.145	<p><b>Upset Defense.</b> In the event of temporary noncompliance with an applicable effluent limitation(s) resulting from an upset at the Permittee's facility due to factors beyond the control of the Permittee, the Permittee has an affirmative defense to an enforcement action brought by the MPCA as a result of the noncompliance if the Permittee demonstrates by a preponderance of competent evidence:</p> <ul style="list-style-type: none"><li>A. The specific cause of the upset;</li><li>B. That the upset was unintentional;</li><li>C. That the upset resulted from factors beyond the reasonable control of the Permittee and did not result from operational error, improperly designed treatment facilities, inadequate treatment facilities, lack of preventative maintenance, or increases in production which are beyond the design capability of the treatment facilities;</li><li>D. That at the time of the upset the facility was being properly operated;</li><li>E. That the Permittee properly notified the Commissioner of the upset in accordance with Minn. R. 7001.1090, subp. 1(I); and</li><li>F. That the Permittee implemented the remedial measures required by Minn. R. 7001.0150, subp. 3(J).</li></ul> <p>[Minn. R. 7001.1090]</p>
5.12.146	<p><b>Release.</b> [Minn. R. 7001]</p>
5.12.147	<p><b>Unauthorized Releases of Wastewater Prohibited.</b> This permit prohibits overflows, discharges, spills, or other releases of wastewater or materials to the environment, whether intentional or not, except for discharges from outfalls specifically authorized by this permit. The MPCA will consider the Permittee's compliance with permit requirements, frequency of release, quantity, type, location, and other relevant factors when determining appropriate action. [Minn. Stat. ch. 115.061]</p>
5.12.148	<p><b>Discovery of a Release.</b> Upon discovery of a release, the Permittee shall:</p> <ul style="list-style-type: none"><li>A. Take all reasonable steps to immediately end the release;</li><li>B. Notify the Minnesota Department of Public Safety Duty Officer at 800-422-0798 or 651-649-5451 (metro area) immediately upon discovery of the release. In addition to the required notification to the Duty Officer, the Permittee may also contact the MPCA during business hours at 800-657-3864 or 651-296-6300 (metro area);</li><li>C. Promptly after notifying the agency of a discharge, a publicly owned treatment works or a publicly or privately owned domestic sewer system owner must provide notice to the potentially impacted public and to any downstream drinking water facility that may be impacted by the discharge. Notice to the public and to any drinking water facility must be made using the most efficient communications system available to the facility owner such as in person, telephone call, radio, social media, web page, or another expedited form. In addition, signage must be posted at all impacted public use areas within the same jurisdiction or notification must be provided to the entity that has jurisdiction over any impacted public use areas. A notice under this paragraph must include the date and time of the discharge, a description of the material released, a warning of the potential public health risk, and the permittee's contact information; and</li><li>D. Recover as rapidly and as thoroughly as possible all substances and materials released or immediately take other action as may be reasonably possible to minimize or abate pollution to waters of the state or potential impacts to human health caused thereby. If the Permittee cannot immediately or completely recover the released materials or substances, the Permittee shall contact the MPCA. If directed by the MPCA, the Permittee shall consult with other local, state, or federal agencies (such as the Minnesota Department of Natural Resources and/or the Wetland Conservation Act authority) for implementation of additional clean up or remediation activities in wetland or other sensitive areas. [Minn. R. 7001.1090, Minn. Stat. ch. 115.061, subp. C]</li></ul>

5.12.149	<p><b>Sampling of a Release.</b> Upon discovery of a release, the Permittee shall:</p> <p>A. Collect representative samples of the release. The Permittee shall sample the release for permitted effluent parameters and other parameters of concern immediately following discovery of the release. The Permittee may contact the MPCA during business hours to discuss the sampling parameters and protocol. In addition, the Permittee shall collect fecal coliform bacteria samples where the Permittee determines that the release contains or may contain sewage. If the Permittee cannot immediately stop the release, the Permittee shall consult with the MPCA regarding additional sampling requirements. The Permittee shall collect samples at least, but not limited to, two times per week for as long as the release continues, or as stipulated elsewhere in this permit;</p> <p>B. The Permittee shall submit the Release Report information according to guidance found here: <a href="https://www.pca.state.mn.us/sites/default/files/wq-wwtp7-20a.docx">https://www.pca.state.mn.us/sites/default/files/wq-wwtp7-20a.docx</a>. The Permittee shall submit the Release Report to the MPCA with the next eDMR or within 30 days, whichever is sooner. If the Permittee submits quarterly eDMRs and the next submittal is greater than 30 days, the Release Report may be submitted to the water quality submittals email address (see the Submitting Reports part of this chapter); and</p> <p>C. Submit the sampling results on the Release Report located on the MPCA's website at <a href="https://www.pca.state.mn.us/business-with-us/discharge-monitoring-reports">https://www.pca.state.mn.us/business-with-us/discharge-monitoring-reports</a>. [Minn. R. 7001.1090]</p>
5.12.150	<p><b>Bypass.</b> [Minn. R. 7001]</p>
5.12.151	<p>"Essential Maintenance" is a scheduled maintenance event that is required to ensure efficient operation of the facility. [Minn. R. 7001.1020, subp. 13]</p>
5.12.152	<p>"Effluent limitation" means a restriction established by rule or permit condition on quantities, discharge rates, and concentrations of pollutants that are discharged from point sources into waters of the state. [Minn. R. 7001.1020, subp. 13]</p>
5.12.153	<p><b>Anticipated Bypass.</b> The Permittee may allow any bypass to occur that does not cause effluent limitation exceedances, but only if the bypass is for a scheduled essential maintenance event to assure efficient operation of the facility. The Permittee shall submit prior notice to the MPCA at least ten days before the date of the bypass, if possible. The notice of the need for an anticipated bypass shall include the following information:</p> <p>A. The proposed date and estimated duration of the bypass;</p> <p>B. The alternatives to bypassing; and</p> <p>C. A proposal for effluent sampling during the bypass. Any bypass wastewater shall enter waters of the state from outfalls specifically authorized by this permit. Therefore, the Permittee shall collect samples at the frequency and location identified in this permit or two times per week for as long as the bypass continues, whichever is more frequent. [Minn. R. 7001.1090, subp. 1(J)]</p>
5.12.154	<p>Any bypass that is not anticipated for a scheduled essential maintenance event is considered unanticipated and is prohibited. This permit prohibits all other bypasses.</p> <p>In the event of an unanticipated bypass, the Permittee shall:</p> <p>A. Take all reasonable steps to immediately end the bypass;</p> <p>B. Notify the Minnesota Department of Public Safety Duty Officer at 800-422-0798 or 651-649-5451 (metro area) immediately upon commencement of the bypass. In addition to the required notification to the Duty Officer, the Permittee may also contact the MPCA during business hours at 800-657-3864 or 651-296-6300 (metro area);</p> <p>C. Immediately take action as may be reasonably possible to minimize or abate pollution to waters of the state or potential impacts to human health caused thereby. If directed by the MPCA, the Permittee shall consult with other local, state, or federal agencies for implementation of abatement, clean up, or remediation activities; and</p> <p>D. The Permittee shall collect samples at the frequency and location identified in this permit or two times per week for as long as the bypass continues, whichever is more frequent. The Permittee shall also follow the reporting requirements for effluent violations as specified in this permit. [Minn. R. 7001.1090, subp. 1(K), Minn. Stat. ch. 115.061]</p>

5.12.155	<p><b>Notification of the Public.</b> Following immediate notification to the Minnesota Department of Public Safety Duty Officer and the MPCA of any discharge event that could endanger human health, public drinking water supplies, or the environment, or a Release or Bypass, as described above, the Permittee shall promptly notify the public and any drinking water facility of the discharge.</p> <p>Notice to the public and to any drinking water facility must be made using the most efficient communications system available to the facility owner such as in person, telephone call, radio, social media, webpage, or another expedited form. In addition, signage must be posted at all impacted public use areas within the same jurisdiction or notification must be provided to the entity that has jurisdiction over any impacted public use areas. A notice under this requirement must include the date and time of the discharge, a description of the material released, a warning of the potential public health risk, and the Permittee's contact information. [Minn. Stat. ch. 115.061]</p>
5.12.156	<p>In addition to other facts or incidents required by the permit to be reported within 24 hours, the Permittee shall report in accordance with part 7001.0150, subpart 3, item K any unanticipated bypass, or upset that causes an exceedance of an applicable effluent limitation. [Minn. R. 7001.1090, subp. 1]</p>
5.12.157	<p><b>Operation and Maintenance.</b> [Minn. R. 7001]</p>
5.12.158	<p>The Permittee shall at all times properly operate and maintain the facilities, sewer system, and systems of treatment and control, and the appurtenances related to them which are installed or used by the Permittee to achieve compliance with the conditions of the permit. Proper operation and maintenance includes effective performance, adequate funding, adequate operator staffing and training, and adequate laboratory and process controls, including appropriate quality assurance procedures. The Permittee shall install and maintain appropriate backup or auxiliary facilities if they are necessary to achieve compliance with the conditions of the permit and, for all permits other than hazardous waste facility permits, if these backup or auxiliary facilities are technically and economically feasible. [Minn. R. 7001.0150, subp. 3(F)]</p>
5.12.159	<p>In the event of a reduction or loss of effective treatment of wastewater at the facility, the Permittee shall control production or curtail discharges to the extent necessary to maintain compliance with the terms and conditions of this permit. The Permittee shall continue this control or curtailment until they restore facility treatment processes or until the Permittee provides an alternative method of treatment. [Minn. R. 7001.1090, subp. 1(C)]</p>
5.12.160	<p><b>Solids Management.</b> The Permittee shall properly store, transport, and manage biosolids, septage, sediments, residual solids, filter backwash, screenings, oil, grease, and other substances so that pollutants do not enter surface waters or groundwaters of the state. The Permittee shall manage solids in accordance with local, state, and federal requirements. [40 CFR 503, Minn. R. 7041]</p>
5.12.161	<p><b>Scheduled Maintenance.</b> The Permittee shall schedule maintenance of the treatment works during non-critical water quality periods to prevent water quality degradation, except where the facility requires emergency maintenance to prevent a condition that would be detrimental to water quality or human health. [Minn. R. 7001.0150, subp. 2(B), Minn. R. 7001.0150, subp. 3(F)]</p>
5.12.162	<p><b>Control Tests.</b> The Permittee shall conduct in-plant control tests at a frequency adequate to ensure compliance with the conditions of this permit. [Minn. R. 7001.0150, subp. 2(B), Minn. R. 7001.0150, subp. 3(F)]</p>
5.12.163	<p><b>Changes to the Facility or Permit.</b> [Minn. R. 7001]</p>
5.12.164	<p><b>Permit Modifications.</b> Except as provided under Minn. Stat. ch. 115.07, subd. 1 and 3, no person required by statute or rule to obtain a permit may construct, install, modify, or operate the facility to be permitted, nor shall a person commence an activity for which a permit is required by statute or rule until the MPCA issues a written permit for the facility or activity.</p> <p>Permittees that propose to make changes to the facility or discharge that requires permit modification shall follow Minn. R. 7001.0190. If the Permittee cannot determine whether the proposed changes require a permit modification, the Permittee shall contact the MPCA prior to any action. The MPCA recommends that Permittees submit the application for permit modification to the MPCA at least 180 days prior to the planned change. [Minn. R. 7001.0030]</p>

5.12.165	<p>This permit does not require plans, specifications, and MPCA approval when maintenance dictates the need for installation of new equipment, provided the equipment is the same design size and has the same design intent. For instance, Permittees can replace a broken pipe, lift station pump, aerator, or blower with the same design-sized equipment without MPCA approval.</p> <p>If this permit does not expressly authorize proposed construction, the MPCA may require a permit modification. If the proposed construction project requires an Environmental Assessment Worksheet under Minn. R. 4410, no construction shall begin until the MPCA issues a negative declaration and the Permittee receives or implements all approvals. [Minn. R. 7001.0030]</p>
5.12.166	<p><b>Report Changes.</b> The Permittee shall give advance notice as soon as possible to the MPCA of any substantial changes in operational procedures, activities that may alter the nature or frequency of the discharge, and/or material factors that may affect compliance with the conditions of this permit. [Minn. R. 7001.0150, subp. 3(M)]</p>
5.12.167	<p><b>Chemical Additives.</b> The Permittee shall receive prior written approval from the MPCA before increasing the use of a chemical additive authorized by this permit, or using a chemical additive not authorized by this permit, in quantities or concentrations that have the potential to change the characteristics, nature, and/or quality of the discharge.</p> <p>The Permittee shall request approval for an increase or new use of a chemical additive at least 60 days, or as soon as possible, before the proposed increase or new use. The Permittee shall include at least the following information for the proposed additive as instructed in the chemical additive approvals section on the MPCA's website at <a href="https://www.pca.state.mn.us/business-with-us/wastewater-permit-additional-guidance-and-information">https://www.pca.state.mn.us/business-with-us/wastewater-permit-additional-guidance-and-information</a> (under Chemical additive approvals):</p> <ul style="list-style-type: none"><li>A. Follow Chemical Additive Review Guidance (wq-prm2-12) and complete the Chemical Additive calculator tool (wq-wwprm2-12a.xlsm), including;</li><li>B. The process for which the additive will be used;</li><li>C. Safety Data Sheet (SDS) which shall include aquatic toxicity, human health, and environmental fate information for the proposed additive. The aquatic toxicity information shall include at minimum the results of: a) a 48-hour LC50 or EC50 acute study for a North American freshwater planktonic crustacean (such as Ceriodaphnia or Daphnia sp.) and b) a 96-hour LC50/EC50 acute study such as rainbow trout, bluegill, or fathead minnow or another North American freshwater aquatic species other than a planktonic crustacean;</li><li>D. A complete product use and instruction label;</li><li>E. The commercial and chemical names and Chemical Abstract Survey (CAS) number for all ingredients in the additive (If the SDS does not include information on chemical composition, including percentages for each ingredient totaling to 100%, the Permittee shall contact the supplier to have this information provided); and</li><li>F. The proposed method of application, application frequency, and maximum rates of use.</li></ul> <p>Upon review of the information submitted regarding the proposed chemical additive, the MPCA may require additional information be submitted for consideration. This permit may be modified to restrict the use or discharge of a chemical additive and include additional influent and effluent monitoring requirements. Approval for the use of an additive or use of an additive not requiring formal review and approval shall not justify the exceedance of any effluent limitation nor shall it be used as a defense against pollutant levels in the discharge causing or contributing to the violation of a water quality standard, including nuisance conditions and material discoloration. [Minn. R. 7001.0170]</p>
5.12.168	<p><b>MPCA-Initiated Permit Modification, Suspension, or Revocation.</b> The MPCA may modify or revoke and reissue this permit pursuant to Minn. R. 7001.0170. The MPCA may revoke without reissuance of this permit pursuant to Minn. R. 7001.0180. [Minn. R. 7001.0170, Minn. R. 7001.0180]</p>

5.12.169	<p><b>Total Maximum Daily Load (TMDL) Impacts.</b> The MPCA may require facilities that discharge to an impaired surface water, watershed, or drainage basin to comply with additional permits or permit requirements. These requirements can include additional restriction or relaxation of limits and monitoring as authorized by the CWA 303(d)(4)(A) and 40 CFR ch. 122.44(l)(2)(i), necessary to ensure consistency with the assumptions and requirements of any applicable EPA approved wasteload allocations resulting from TMDL studies. [40 CFR 122.44(l)(2)(i)]</p>
5.12.170	<p><b>Permit Transfer.</b> This permit is not transferable to any person without the express written approval of the MPCA after compliance with the requirements of Minn. R. 7001.0190. A person who receives permit transference shall comply with the conditions of this permit. [Minn. R. 7001.0150, subp. 3(N)]</p>
5.12.171	<p><b>Facility Closure or Significant Reduction in Activity.</b> The Permittee is responsible for closure and post-closure care of the facility. The Permittee shall notify the MPCA of a significant reduction or cessation of the activities described in this permit at least 180 days before the reduction or cessation. The Permittee may submit a Facility Closure Plan to the MPCA no later than 150 days prior to the Facility Closure, and the MPCA may require submittal of a Facility Closure Plan via written notification. The Permittee may comply with the submitted Facility Closure Plan.</p> <p>The MPCA may require a permit modification or reissuance for facility closure that could result in a potential long-term water quality concern, such as the ongoing discharge of wastewater to surface or groundwater.</p> <p>The MPCA may require the Permittee to establish and maintain financial assurance to ensure performance of certain obligations under this permit, including closure, post-closure care, and remedial action at the facility. If the MPCA requires financial assurance, the MPCA shall approve the amount and type of financial assurance, and proposed modifications to previously MPCA-approved financial assurance. [Minn. Stat. ch. 116.07, subd. 4]</p>
5.12.172	<p><b>Permit Reissuance.</b> If the Permittee desires to continue permit coverage beyond the date of permit expiration, the Permittee shall submit an application for permit reissuance: due by 180 days prior to permit expiration. [Minn. R. 7001.0040]</p>
5.12.173	<p>If the Permittee does not intend to continue the activities authorized by this permit after the expiration date of this permit, the Permittee shall notify the MPCA in writing at least 180 days before permit expiration. If the Permittee has submitted a timely application for permit reissuance, the Permittee may continue to conduct the activities authorized by this permit, in compliance with the requirements of this permit, until the MPCA takes final action on the application, unless the MPCA determines any of the following:</p> <ul style="list-style-type: none"> <li>A. The Permittee is not in substantial compliance with the requirements of this permit, or with a stipulation agreement or compliance schedule designed to bring the Permittee into compliance with this permit;</li> <li>B. The MPCA, as a result of an action or failure to act by the Permittee, has been unable to take final action on the application on or before the expiration date of the permit; or</li> <li>C. The Permittee has submitted an application with major deficiencies or has failed to properly supplement the application in a timely manner after being informed of deficiencies. [Minn. R. 7001.0040, Minn. R. 7001.0160]</li> </ul>

6. Submittal action summary

SD 001	Effluent To Surface Water	
		<b>Surface Discharge: Class A Major Facility Effluent Requirements</b>
	6.1.1	The Permittee shall submit a monthly DMR: due by 21 days after the end of each calendar month following permit issuance. [Minn. R. 7001.0150, subp. 2(B)]
		<b>Acute Toxicity Requirements</b>
	6.2.2	The Permittee shall submit annual acute toxicity test battery results: due 180 calendar days after Permit Issuance Date annually thereafter. [Minn. R. 7001]
		<b>Priority Pollutant Requirements</b>
	6.3.3	The Permittee shall submit the first priority pollutant monitoring report: due 1095 calendar days before Permit Expiration Date. (By two years after permit issuance date). [Minn. R. 7001]
	6.3.4	The Permittee shall submit the second priority pollutant monitoring report: due 730 calendar days before Permit Expiration Date. (By three years after permit issuance date). [Minn. R. 7001]
	6.3.5	The Permittee shall submit the third priority pollutant monitoring report: due 365 calendar days before Permit Expiration Date. (By four years after permit issuance date). [Minn. R. 7001]
WS 001	Influent Waste	
		<b>Waste Stream: Class A Major Facility Influent Requirements</b>
	6.4.1	The Permittee shall submit a monthly DMR: due by 21 days after the end of each calendar month following permit issuance. [Minn. R. 7001.0150, subp. 2(B)]
MN0020567	Monticello WWTP	
		<b>Pretreatment: Nondelegated Requirements</b>
	6.5.1	The Permittee shall submit a Pretreatment Annual Report: due by 31 days after the end of each calendar year following permit issuance if a SIU discharges to the POTW during a given calendar year. [Minn. R. 7049]
		<b>Biosolids: Land Application</b>
	6.6.2	The Permittee shall submit a Biosolids Annual Report: due annually, by the 31st of December. [Minn. R. 7041.1700]
		<b>Total Facility Requirements (NPDES/SDS)</b>
	6.7.3	<b>Permit Reissuance.</b> If the Permittee desires to continue permit coverage beyond the date of permit expiration, the Permittee shall submit an application for permit reissuance: due by 180 days prior to permit expiration. [Minn. R. 7001.0040]

**7. Limits and monitoring**

The Permittee shall comply with the limits and monitoring requirements as specified below.

Subject item	Parameter	Discharge limitations							Monitoring requirements			Notes
		Quantity /Loading avg.	Quantity /Loading max.	Quantity /Loading units	Quality /Conc. min.	Quality /Conc. avg.	Quality /Conc. max.	Quality/ Conc. units	Frequency	Sample type	Effective period	
SD 001 Surface Water Discharge	BOD, Carbonaceous 05 Day (20 Deg C)	114 calendar month average	182 maximum calendar week average	kilograms per day		25 calendar month average	40 maximum calendar week average	milligrams per liter	3 times per week	24-Hour Flow Composite	Jan-Dec	
SD 001 Surface Water Discharge	BOD, Carbonaceous 05 Day (20 Deg C) Percent Removal				85 minimum calendar month average			percent	once per month	Calculation	Jan-Dec	
SD 001 Surface Water Discharge	Chloride, Total						Monitor only. calendar month maximum	milligrams per liter	once per month	24-Hour Flow Composite	Jan-Dec	
SD 001 Surface Water Discharge	Chlorine, Total Residual						0.038 daily maximum	milligrams per liter	once per day	Grab	Apr-Oct	
SD 001 Surface Water Discharge	Fecal Coliform, MPN or Membrane Filter 44.5C					200 calendar month geometric mean		organisms per 100 milliliter	3 times per week	Grab	Apr-Oct	
SD 001 Surface Water Discharge	Flow		Monitor only. calendar month total	million gallons		Monitor only. calendar month average	Monitor only. calendar month maximum	million gallons per day	once per day	Measurement, Continuous	Jan-Dec	
SD 001 Surface Water Discharge	Mercury, Dissolved (as Hg)					Monitor only. calendar month average	Monitor only. daily maximum	nanograms per liter	twice per month	Grab	Jan, Mar, May, Jul, Sep, Nov	
SD 001 Surface Water Discharge	Mercury, Total (as Hg)					10 calendar month average	17 daily maximum	nanograms per liter	twice per month	Grab	Jan, Mar, May, Jul, Sep, Nov	

Subject item	Parameter	Discharge limitations						Monitoring requirements				Notes
		Quantity /Loading avg.	Quantity /Loading max.	Quantity /Loading units	Quality /Conc. min.	Quality /Conc. avg.	Quality /Conc. max.	Quality/ Conc. units	Frequency	Sample type	Effective period	
SD 001 Surface Water Discharge	Nitrite Plus Nitrate, Total (as N)					Monitor only. calendar month average		milligrams per liter	once per month	24-Hour Flow Composite	Jan-Dec	
SD 001 Surface Water Discharge	Nitrogen, Ammonia, Total (as N)					Monitor only. calendar month average		milligrams per liter	once per month	24-Hour Flow Composite	Jan-Dec	
SD 001 Surface Water Discharge	Nitrogen, Kjeldahl, Total					Monitor only. calendar month average		milligrams per liter	once per month	24-Hour Flow Composite	Jan-Dec	
SD 001 Surface Water Discharge	Nitrogen, Total (as N)					Monitor only. calendar month average		milligrams per liter	once per month	Calculation	Jan-Dec	
SD 001 Surface Water Discharge	Oxygen, Dissolved				Monitor only. calendar month minimum			milligrams per liter	once per day	Grab	Jan-Dec	
SD 001 Surface Water Discharge	pH				6.0 calendar month minimum		9.0 calendar month maximum	standard units	once per day	Grab	Jan-Dec	
SD 001 Surface Water Discharge	Phosphorus, Total (as P)	Monitor only. calendar month average		kilograms per day		Monitor only. calendar month average		milligrams per liter	once per week	24-Hour Flow Composite	Jan-Dec	
SD 001 Surface Water Discharge	Phosphorus, Total (as P)		2608 12-month moving total	kilograms per year					once per month	Calculation	Jan-Dec	
SD 001 Surface Water Discharge	Solids, Total Dissolved (TDS)						Monitor only. calendar month maximum	milligrams per liter	once per month	24-Hour Flow Composite	Jan-Dec	

Subject item	Parameter	Discharge limitations							Monitoring requirements			Notes
		Quantity /Loading avg.	Quantity /Loading max.	Quantity /Loading units	Quality /Conc. min.	Quality /Conc. avg.	Quality /Conc. max.	Quality/ Conc. units	Frequency	Sample type	Effective period	
SD 001 Surface Water Discharge	Solids, Total Suspended (TSS)	136 calendar month average	204 maximum calendar week average	kilograms per day		30 calendar month average	45 maximum calendar week average	milligrams per liter	3 times per week	24-Hour Flow Composite	Jan-Dec	
SD 001 Surface Water Discharge	Solids, Total Suspended (TSS) Percent Removal				85 minimum calendar month average			percent	once per month	Calculation	Jan-Dec	
SD 001 Surface Water Discharge	Solids, Total Suspended (TSS), grab (Mercury)					Monitor only. calendar month average	Monitor only. daily maximum	milligrams per liter	twice per month	Grab	Jan, Mar, May, Jul, Sep, Nov	
SD 001 Surface Water Discharge	Specific Conductance						Monitor only. calendar month maximum	micromhos per cm	once per month	Measurement	Jan-Dec	
SD 001 Surface Water Discharge	Sulfate, Total (as SO4)						Monitor only. calendar month maximum	milligrams per liter	once per month	24-Hour Flow Composite	Jan-Dec	
WS 001 Influent Waste Stream	BOD, Carbonaceous 05 Day (20 Deg C)					Monitor only. calendar month average	Monitor only. calendar month maximum	milligrams per liter	3 times per week	24-Hour Flow Composite	Jan-Dec	
WS 001 Influent Waste Stream	Flow		Monitor only. calendar month total	million gallons		Monitor only. calendar month average	Monitor only. calendar month maximum	million gallons per day	once per day	Measurement, Continuous	Jan-Dec	
WS 001 Influent Waste Stream	Mercury, Total (as Hg)					Monitor only. calendar month average		nanograms per liter	twice per month	Grab	Jan, Mar, May, Jul, Sep, Nov	
WS 001 Influent Waste Stream	Nitrite Plus Nitrate, Total (as N)					Monitor only. calendar month average		milligrams per liter	once per month	24-Hour Flow Composite	Jan-Dec	
WS 001 Influent Waste Stream	Nitrogen, Kjeldahl, Total					Monitor only. calendar month average		milligrams per liter	once per month	24-Hour Flow Composite	Jan-Dec	

Subject item	Parameter	Discharge limitations							Monitoring requirements			Notes
		Quantity /Loading avg.	Quantity /Loading max.	Quantity /Loading units	Quality /Conc. min.	Quality /Conc. avg.	Quality /Conc. max.	Quality/ Conc. units	Frequency	Sample type	Effective period	
WS 001 Influent Waste Stream	Nitrogen, Total (as N)					Monitor only. calendar month average		milligrams per liter	once per month	Calculation	Jan-Dec	
WS 001 Influent Waste Stream	pH				Monitor only. calendar month minimum		Monitor only. calendar month maximum	standard units	once per day	Grab	Jan-Dec	
WS 001 Influent Waste Stream	Phosphorus, Total (as P)					Monitor only. calendar month average		milligrams per liter	once per week	24-Hour Flow Composite	Jan-Dec	
WS 001 Influent Waste Stream	Precipitation		Monitor only. calendar month total	inches					once per day	Measurement	Jan-Dec	
WS 001 Influent Waste Stream	Solids, Total Suspended (TSS)					Monitor only. calendar month average	Monitor only. calendar month maximum	milligrams per liter	3 times per week	24-Hour Flow Composite	Jan-Dec	